

# SEPAR FILTER

## SEPAR 2000

### SWK 2000/10/U

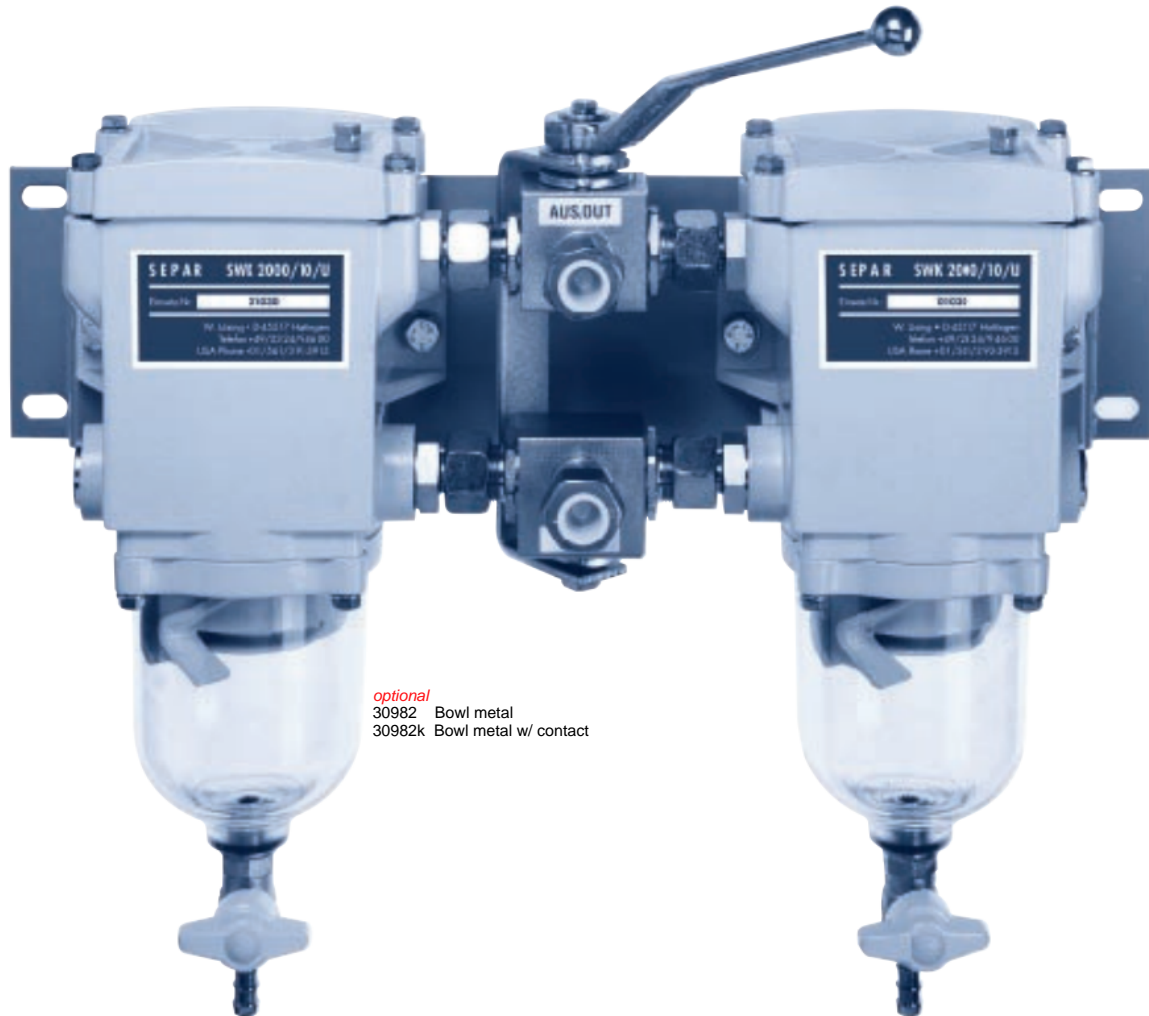

*optional*  
30982 Bowl metal  
30982k Bowl metal w/ contact

POS.	ARTIKEL-NR. ARTICLE NR.	STÜCK PIECES	BENENNUNG	DESCRIPTION	POS.	ARTIKEL-NR. ARTICLE NR.	STÜCK PIECES	BENENNUNG	DESCRIPTION
1	30408	2	Entlüftungsschraube	bleed valve	15	40002	2	Dichtung	gasket
2	30567	8	Schraube (Deckel)	screw (lid)	16	30366	2	Ablafshahn	drain cock
3	30553	2	Deckel	lid	17	30560	2	Schraube	screw
4	30556	2	Deckeldichtung	lid gasket	18	30558	2	Dichtung f. Pos. 1	gasket f. Pos. 1
5	30297	2	Federkassette	spring cassette	19	40003	8	Dichtung f. Pos. 13	gasket f. Pos. 13
6	01030	2	Filter-Einsatz	filter element	20	30133	4	Schraube	screw
7	30448	16	U-Scheibe	washer	21	30022	4	Sicherungsmutter	lock nut
8	30552	2	Gehäuse	housing	22	30021	8	U-Scheibe	washer
9	30576	2	Dichtung Bowlenhaltering	bowl gasket	23	30102-1	4	Ger.Verschraubung	straight fitting
10	30569	2	Bowlenhaltering	bowl retainer ring	24	30476	1	Umschaltventil	reversing valve
11	30563	2	Zentrifuge	centrifuge	25	30477	1	Montageplatte	mounting plate
12	30568	8	Schraube (Bowlenhaltering)	screw (for bawl retainer ring)	26	30491	1	Umlenkebel	reversing lever
13	30226	4	Verschluß-Stopfen	blind screw	27	30247	2	Ü-Mutter	union nut
14	30985	2	Bowle	bowl	28	30248	2	Schneidring	cutting ring

## SEPAR 2000

SWK 2000/10/U

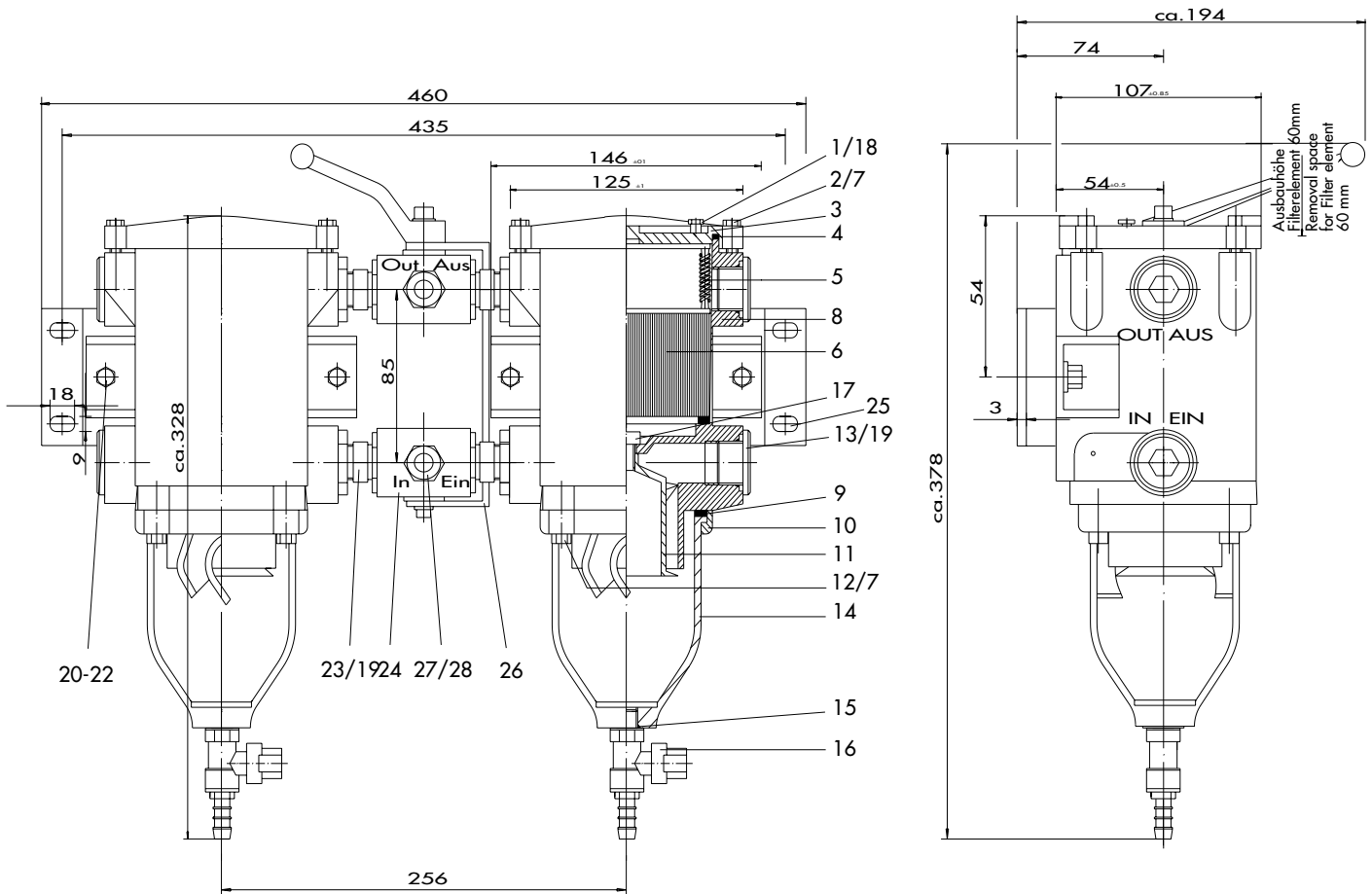

### FLUSSDIAGRAMM · FLOW DIAGRAMM

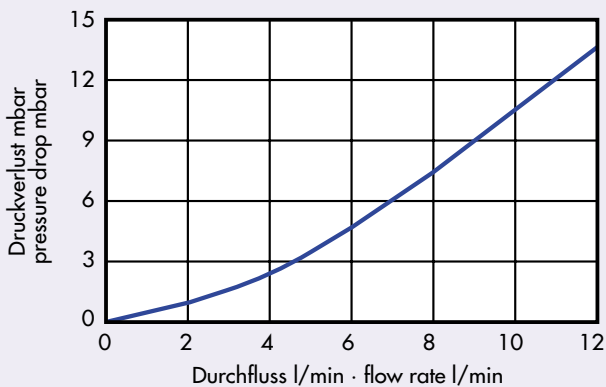

Technische Änderungen vorbehalten  
We reserve the right to make technical changes without notification

**Willibrord Lösing**  
Filter-Technik



Postfach 86 6009  
45517 Hattingen  
Essener Straße 108  
45529 Hattingen  
Telefon 023 24/9 46 00  
Telefax 023 24/408 42

Max. Durchflussmenge: 10 l/min Anschluss: 15 mm Rohr Ø  
Max. flow rate: 10 l/min Connection: 15 mm Pipe Ø